



# Gain complementary capabilities with Figaro and Invoq

WHITE PAPER

The Figaro multifunctional braising pan and the Invoq combi oven is a dynamic duo providing unparalleled kitchen versatility, all while optimising time and cost savings. Combined these units cover >90% of the common cooking techniques.

We've got you covered:

- Space efficiency
- Time efficiency
- Energy efficiency

## Kitchens' need for flexibility and versatility

In the foodservice industry, a multitude of equipment is necessary to tackle the diverse array of daily culinary responsibilities. Joining forces to simplify your processes, save valuable kitchen space as well as time while ensuring enhanced food quality, these two powerful and central kitchen appliances will cover everything from steaming and boiling to grilling and frying catering to you and your customer's needs for versatile cooking styles and menu items.

## A perfect culinary pairing

Most operators are faced with challenges pertaining the need to cater to customers changing tastes, emerging food trends and fluctuations in accessibility of food items. Therefore, you need equipment to multitask, be quick and efficient.

Combined the Figaro multifunctional braising pan and the Invoq combi oven encompass >90% of the prevalent cooking methods.

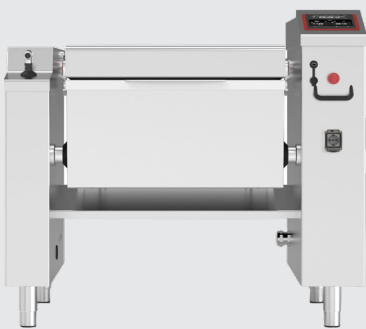

Figaro DFIE100A

- Boiling
- Braising
- Pan frying
- Deep-frying
- Steam cooking
- Pressure cooking
- Sous vide



Invoq Combi 10-1/1 GN

- Poaching
- Steaming
- Sous vide
- Braising
- Roasting
- Slow-cooking
- Pan frying
- Baking
- Defrosting
- Proving
- Baking
- Dehydrating
- Regenerating

## Energy and space efficiency

By using these two units in tandem you can optimise the energy consumption in your kitchen. Not only because your kitchen design will necessitate fewer power-hungry kitchen appliances but also thanks to the innovative power control capabilities of these two units.

Particularly beneficial for smaller kitchens, canteens or other foodservice establishments with limited space, a solution with Figaro and Invoq working side by side will save valuable floor space, as they fulfil most requirements with only two units compared to the previous need of up to six different equipment.

For large scale kitchen with bulk cooking needs, the solution with a 150L Figaro and a 20-grid roll-in Invoq will offer great efficiency by streamlining your food preparation process and ensuring that you have the capacity to meet high-demand situations.

## Reduce your labour costs

The automation and ease of use of these two systems can help you reduce the labour cost related to cooking tasks, allowing your staff to focus on other priorities. The simplicity and intuitive appeal of the common touch control user interface makes the experience and usability comfortable and easy. The unification gives consistency and thus a high quality in learnability.

## Visible food safety and consistent food quality

Both Figaro and Invoq come with integrated HACCP monitoring, helping you maintain food safety standard and compliance with regulations. Your HACCP files are automatically stored and can be downloaded in PDF format to validate your food safety and quality documentation.

TRADITIONAL KITCHEN LAYOUT

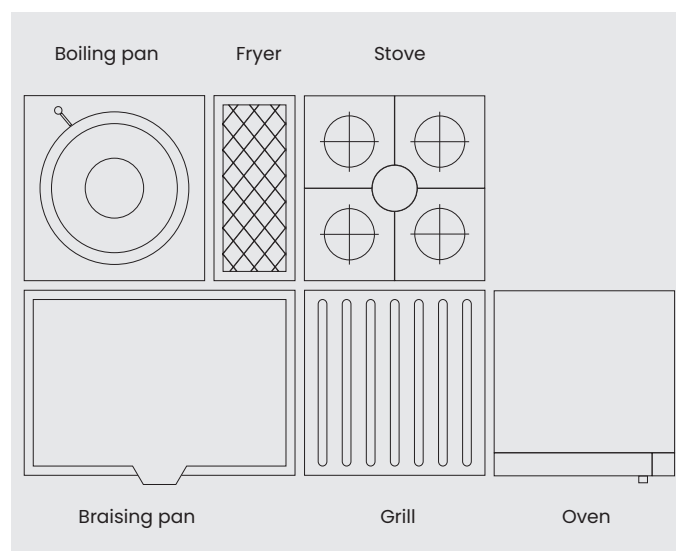

FIGARO + INVOQ KITCHEN LAYOUT

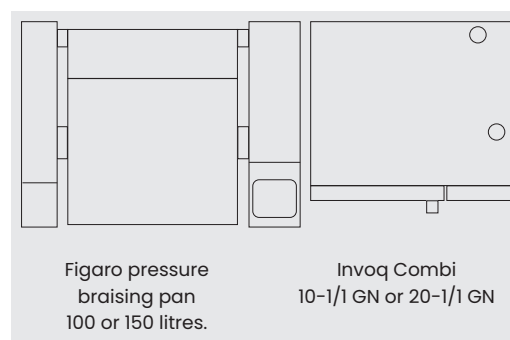

Simple as a smartphone

Intuitive to use by any member of your team

Enhanced and simple food safety documentation

## Scale when demand grows

As your business expands, you can easily scale up by incorporating additional Figaro and Invoq units as needed thanks to their user-friendly shared control panel eliminating the need for staff to undergo training in different types of equipment.

Both units are also cloud connected allowing you to take advantage of the Open Kitchen platform for monitoring and recipe distribution. You can update all units in your fleet with the click of a button.

Same control panel  
- Learn one, use both



## Let's get factual

### Figaro

- Time saving of 30-40%\*
- Energy saving of 40-70%\*
- Water saving of 70%\*
- Versatile in cooking, quick in heating, compact in size
- A new heating technology makes Figaro 4 times faster than a traditional braising pan
- Goes from 18°C to 200°C in just 3 minutes
- Pressure cook using up to max. 0,45 bar
- Highly accurate temperature control
- Less product waste using pressure management

### Invoq

- Advanced technology made simple
- Steam technology reinvented with options of injection steam and hybrid steam
- Boots in less than 3 seconds
- 17% more capacity in Invoq Combi 6-1/1 GN\*\*
- 70% less energy in steam\*\*
- Recirculating cost-effective CareCycle cleaning system
- CareCycle uses 27% less water and 63% less time\*\*
- Intelligent oven features guides and assists your cooking and increases yield
- Combi modes gives faster and more accurate cooking results

\*Comparisons are made up against traditional braising pan without pressure.

\*\*Comparisons are made up against the precessor models.