

F I G

A R O







**What your recipe needs**

**08**

**Company**

**Figaro**

**10**

**Innovative  
touch screen**

**12**

**Word to  
the chef**

**14**

**The kitchen  
of the future  
is Firex**

**16**

**Clever  
heating**

**18****Pressure  
cooking****21****Why  
Figaro****22****Cooking  
processes****24****Accessories****26****Energy  
savings****27****Technical  
features**

# F I G

**A cooking  
revolution  
for your  
kitchen.**



# A R O

**Compact  
in size and  
extremely fast  
in heating.**



## Figaro: versatile in cooking, quick in heating, compact in size.

**Figaro** serves as braising pan, kettle, fryer and traditional stove: **one single machine** that offers the possibility of cooking also under pressure.

**A new heating technology** makes Figaro 4 times faster than a traditional braising pan.

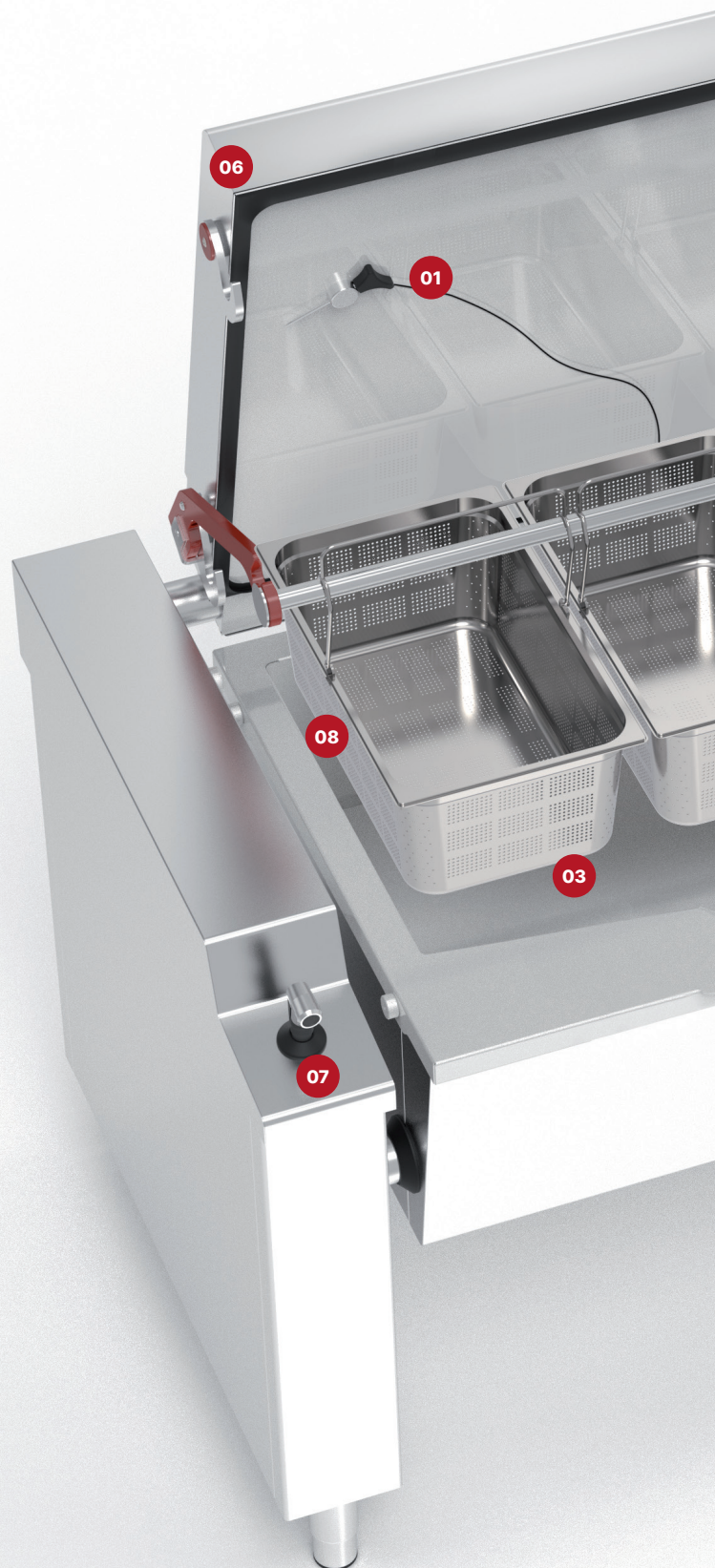

**Power:**



**Capacity:**

100 | 150 litres

Versions with  
pressure cooking  
and drain available.



- 01 **Multi-point core probe**
- 02 **Clever heating of the bottom of the tank**
- 03 **Temperature probe**
- 04 **USB port:**  
download HACCP data and upload/download recipes
- 05 **Figaro Touch Control (FTC):**  
easy and intuitive touch screen
- 06 **Locking hook** for the pressure lid and **basket lifting system**
- 07 **Shower head with flexible joint,** managed by the electronic board
- 08 **Automatic litre meter** for hot and cold water load
- 09 **Drain**
- 10 **SafePour** anti-overflow control when emptying the tank



# Figaro Touch Control (FTC): easy and intuitive touch screen



## New electronic board V2

### The new-generation electronic board.

The **Figaro Touch Control** is the **next-generation** electronic board, extremely user-friendly and suitable to any operator.

It features an **intuitive interface** to create and store complete and customised cooking programs.

**It manages the energy use in autonomy** in order to ensure precise, quick and even reaching of the temperature in the tank.

A technology that guides you step by step through the recipe and demands the operator's intervention only when necessary.

**FTC** is connected to the **"Open kitchen"** cloud platform. You'll be able to monitor: data, consumptions, processes, cooking modes, software updates and any maintenance needs.

# Chef Enrico Pivieri

Restaurant  
**Il Cavallo  
Scosso**  
Asti



**My cuisine is a fusion of various gastronomic traditions of different continents** and my goal is to offer guests a unique taste experience. Lots of different dishes require plenty of resources which is why I was looking for an ally that is able to manage the **high variety of preparations safely and in autonomy**.

Since when we introduced **Figaro** in our kitchen, I can program entire processes and leave it to the machine to complete them. **Figaro** can be used to **braise, boil, fry, steam cook or cook under pressure** and guarantees to achieve always **consistent results** and to have outstanding quality. **Figaro** works smartly and provides **perfect temperature control** and this makes me confident I always serve my guests delicious recipes.



“ **Figaro** can be used to braise, boil, fry, steam cook or cook under pressure ”



# Firex: the kitchen of the future.

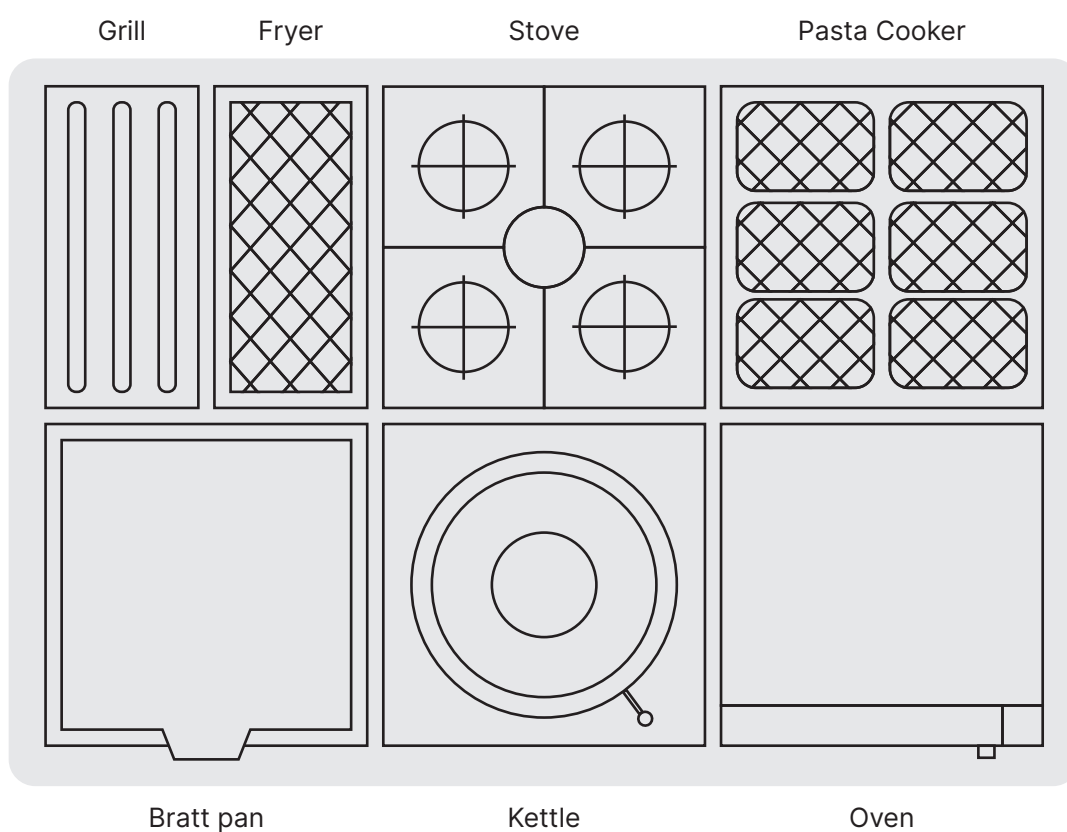

**Traditional kitchen: space used → 4,32 m<sup>2</sup>**

With **Figaro** you get better results while **saving time, space and energy.**

Combine **Figaro** with the multifunctional cooker **Cucimix** and the **Invoq** combi oven to get **multiple advantages**:

- > Fewer units,
- > Less space used,
- > Fewer connections,
- > Fewer hoods,
- > Less floor grating.

**Figaro DFIE100A**

**Invoq Combi 10-1**

**Cucimix 30**

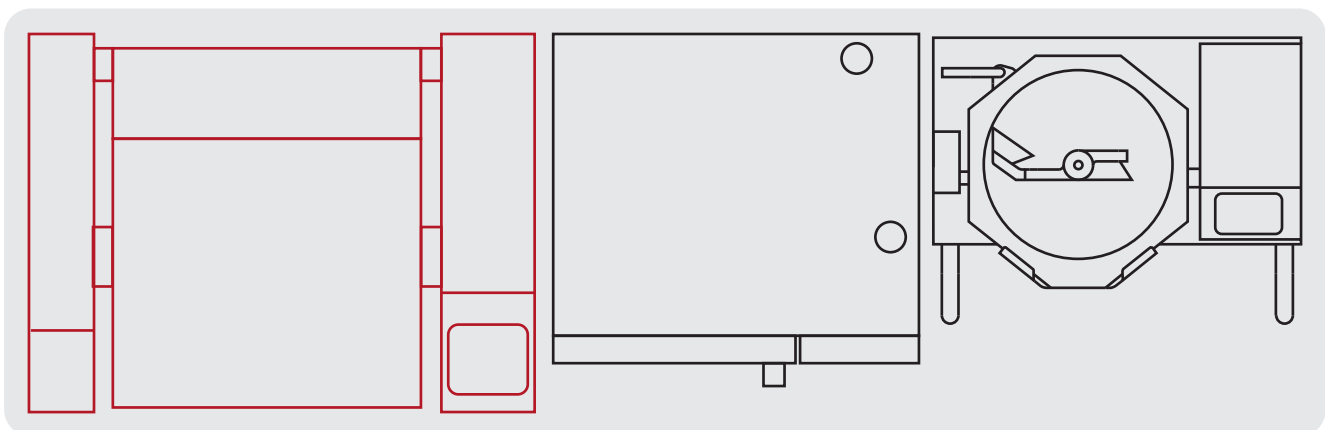

**Firex solution: space used → 2,87 m<sup>2</sup>**



Cucimix 30 CBTE030\_V1



Invoq Combi 10-1/1 GN

# Speed and savings. Even distribution of heat in the tank.

## Heating zones

The heating system of the tank has **6 to 8 ceramic heating zones**, all controlled by the probe.

## Faster with lower consumption

Set temperature is reached extremely quickly:  
**from 18°C to 200°C in 3 minutes.**

## No hot spots

The heat switches off in areas where there is no product. **No more burnt food. Easy cleaning of the tank.**

**Figaro** is able to understand the amount of energy needed in each zone of the tank and therefore adapts the power to the type and quantity of product in complete **autonomy and automatically**. For example the unit is able avoid creation of overheated zones where there is no product, thus facilitating the cleaning operations.



## Clever heating of the bottom of the tank.



### Smart tank heating system

The heating elements cover entirely the bottom of the tank which is divided into **independent zones**. Each one reaches and maintains the desired temperature, adjusting the power according to the needs.

### Increased energy savings

**Zero waste**, only necessary power is used. **The electronic board independently manages the energy** input required to ensure gradual and even temperature reaching in the tank by regulating the power in the heating zones, thanks to constant temperature reading in the different zones.

## Heating zones in the bottom of the tank.

# Faster cooking with pressure.

## A new way of managing pressure.

### Pressure lid – 0.45 bar, 110°C

#### **Clever pressure management:**

electronically controlled, self-regulating temperature in the different heating zones on the bottom of the tank: the working pressure is reached more efficiently.

**Ad hoc pressure:** the electronic board guarantees the perfect pressure in the tank, depending on the type and quantity of the cooking product.

**Less water:** the clever pressure management allows to cook using a minimum amount of water.

#### **No more exhaust vapours in the kitchen:**

safe and fast condensation of vapours, cooled with water.

#### **Higher safety level:**

automatic lid closure with side safety latch, software safety and safety valves.

#### **Motorised systems:**

tilting, lid and basket lifting system.

#### **Altitude management:**

self-regulating settings based on the altitude at which the machine is installed.





# Advantages of pressure cooking.

## Better quality of the finished product

The **flavours remain trapped** in the tank during the cooking process, they are not dispersed in the kitchen space and therefore remain in the finished product.

## Safety and cooking uniformity

Cooking under pressure with **Figaro** means working safely: a series of **electronic and mechanical controls** guarantees complete protection of the operators and the surrounding environment.

An **automatic system** seals the cooking tank hermetically only after detecting no residual air.

**Perfect pressure cooking** is only possible in a steam-saturated environment: this means that the temperature inside the tank is uniform and above 100°C.

Once the cooking is completed, **Figaro** will restore the environmental pressure by rapidly condensing the vapours. The FTC board will signal the possibility of opening the lid only when the environment is safe.

## Easy to clean

After discharging a pressure-cooked product, the **tank will already appear to be almost completely clean**. It will only need a quick rinse before moving on the next cooking cycle.

## More comfort in the working environment

Pressure cooking **does not produce steam evaporation in the kitchen**, there is no heat dispersion and practically no noise. Everything leads to a **healthier working environment**.

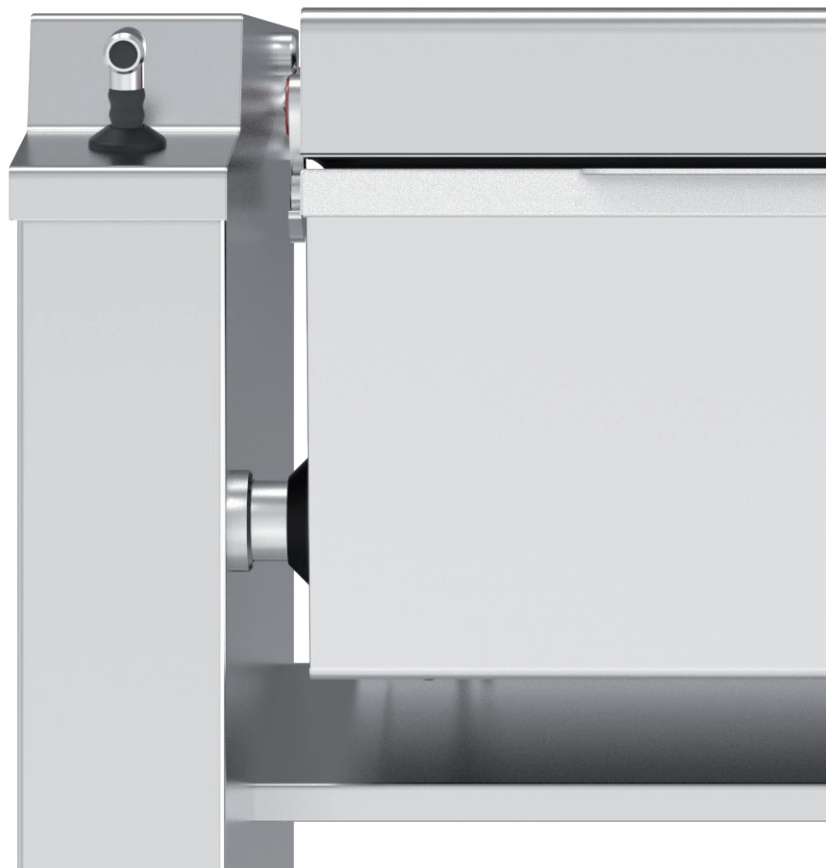

# Figaro is the right choice.

Immediate benefits with **Figaro**.



Time saving (30-40%)



Guaranteed process traceability



Energy saving (40-70%)



Production planning



Water saving (70%)



Healthier work environment  
(less effort = less stress)



Healthier food



Less space occupied



Noise reduction



Less product waste =  
More benefits



**Figaro:  
consistent  
results and  
high quality,  
always.**

# Countless cooking modes for each recipe.

Great versatility, compact in size

## Pressure cooking

The clever management of the different heating zones guarantees a more **efficient management of the pressure in the tank**.

**Reduced water waste and energy consumption**, thanks to the automatic pressure cooking management.



## Braising and browning

**Temperature control of the different heating areas** makes it possible to adjust the heating of the tank until it reaches the precise set temperature, ideal to brown large quantities of product as well as if **using the machine as a fry top**.

**With automatic pre-heating**





### Steam cooking

The little water added to the tank is immediately brought to a boil, creating steam that is retained in the **tank by closing the motorised lid**.

Vegetables can be steam cooked and other delicate cooking processes can take place **extremely quickly with minimum energy consumption**, even when using pressure.



### Boiling

The clever heating system adapts the **heating power in complete autonomy** in order to reach the desired temperature as quickly as possible.

**PianoForte** option available to reach boiling point quicker and to manage it on three levels: simmering - boiling - hard boiling.



### Frying

The electronic board ensures **speed and precision in the oil temperature control**.

You will be able to maintain the correct frying temperature even using frozen products. The machine will be able to manage perfectly the high power required for this type of preparation thanks to the **reactivity of the clever heating system**.

## Figaro accessories.



**Perforated container**  
**For steam cooking or boiling**  
 Perforated container for steam cooking or boiling.

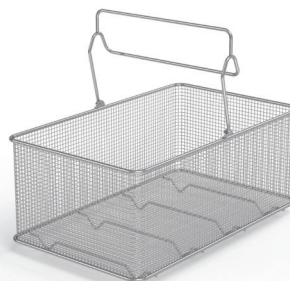

**Frying basket**  
**For maximum ease when frying**  
 Frying container with handle for automatic lifting.



**Omelette spatula**  
**For both sweet and savoury dishes**  
 Practical scraper for perfect omelettes.



**Wheels kit**  
**Better mobility of the machine**  
 Wheels offer the possibility to **move the machine** and be able to reconfigure the kitchen space according to the needs.



**Perforated strainer made of stainless steel**  
**Specifically designed for models with the drain**  
 It is an essential tool for **separating cooking liquids from solid products**. The strainer can be used also when working with the lid closed, thus offering a greater possibility of use.

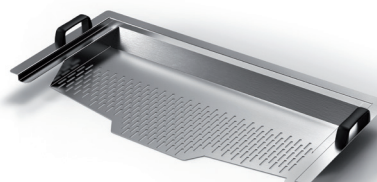

**Strainer**  
**Practical help to separate the product from the cooking liquids**  
 It fits easily on the upper part of the pan and remains firmly attached to the machine for the complete drainage of liquids.



**False bottom made of stainless steel**  
**Ideal for sous-vide cooking or as support stand for Gastronorm trays**

It can serve as stable and resistant platform for various operations. The 100lt version can fit 2 false bottoms, whereas the 150lt can fit 3 false bottoms.



**Non-perforated steel scoop**  
**Perfect for collecting solid products from the bottom of the vessel**

Designed for maximum safety and comfort in use. The rounded end prevents scratching the bottom of the vessel.



**Perforated steel scoop**  
**Perfect for collecting solid products from the bottom of the vessel and draining the liquids**

Designed for maximum safety and comfort in use. The rounded end prevents scratching the bottom of the vessel.

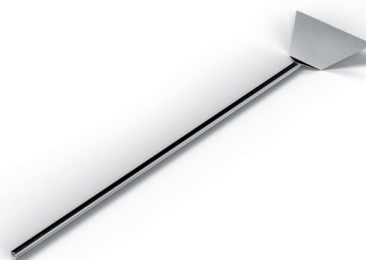

**Long handle spatula**

**Made of stainless steel**  
 Steel designed to help the operator to mix the product

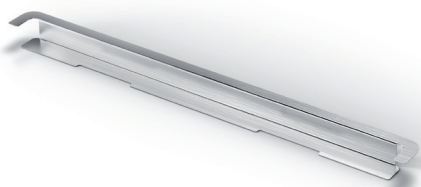

**Gastronorm 1/1 tray holder frame**

Made of two steel bars to be placed on the front and rear edges of the vessel.

**Allows placing of perforated baskets (not included) for steam or pressure cooking.**



**Oil filter trolley**

**Overall capacity 75 lt**  
**Useful capacity 50 lt**

## Figaro vs traditional cooking systems



**Figaro allows you to minimise the cooking times and increase the energy savings.**

**Energy consumption reduced by 40%**

**Quicker temperature reaching**

**Productivity 3 times higher**

**Cooking times reduced by 50-70%**

When cooking under pressure the **tank remains sealed and saturated with steam**. This ensures that temperature is distributed evenly within the tank and **prevents energy losses during the process**, thus increasing productivity and energy savings.

**The clever heating control system provides** only the energy necessary to reach the set temperature. An advanced control system calculates the amount of power to be supplied for each zone in real time.

This technology prevents the creation of hot spots where the product burns, making cleaning operations much easier.

## Technical features

Model  
**100 lt**



Model  
**150 lt**



| Model                | Dimensions (mm)     | Pressure (bar) | Vessel dimensions (mm) | Capacity (lt) | Vessel surface (dm <sup>2</sup> ) | GN containers (nr) | Power (Kw) | Voltage                  | Drain |
|----------------------|---------------------|----------------|------------------------|---------------|-----------------------------------|--------------------|------------|--------------------------|-------|
| <b>DFIE100 V2</b>    | 1296×960<br>h. 1151 | -              | 660×610<br>h. 274      | 102           | 40                                | 2                  | 24.0       | 380-415V 3N<br>~ 50/60Hz | ✗     |
| <b>DFIE100-D V2</b>  | 1296×960<br>h. 1151 | -              | 660×610<br>h. 274      | 102           | 40                                | 2                  | 24.0       | 380-415V 3N<br>~ 50/60Hz | ✓     |
| <b>DFIE100A V2</b>   | 1296×960<br>h. 1151 | 0,45           | 660×610<br>h. 274      | 102           | 40                                | 2                  | 24.0       | 380-415V 3N<br>~ 50/60Hz | ✗     |
| <b>DFIE100A-D V2</b> | 1296×960<br>h. 1151 | 0,45           | 660×610<br>h. 274      | 102           | 40                                | 2                  | 24.0       | 380-415V 3N<br>~ 50/60Hz | ✓     |
| <b>DFIE150 V2</b>    | 1648×960<br>h. 1151 | -              | 1040×610<br>h. 274     | 157           | 63                                | 3                  | 38.5       | 380-415V 3N<br>~ 50/60Hz | ✗     |
| <b>DFIE150-D V2</b>  | 1648×960<br>h. 1151 | -              | 1040×610<br>h. 274     | 157           | 63                                | 3                  | 38.5       | 380-415V 3N<br>~ 50/60Hz | ✓     |
| <b>DFIE150A V2</b>   | 1648×960<br>h. 1151 | 0,45           | 1040×610<br>h. 274     | 157           | 63                                | 3                  | 38.5       | 380-415V 3N<br>~ 50/60Hz | ✗     |
| <b>DFIE150A-D V2</b> | 1648×960<br>h. 1151 | 0,45           | 1040×610<br>h. 274     | 157           | 63                                | 3                  | 38.5       | 380-415V 3N<br>~ 50/60Hz | ✓     |

## Contact us

HOUNÖ A/S

Alsvej 1

8940 Randers SV

Denmark

T: +45 8711 4711

M: [houno@houno.com](mailto:houno@houno.com)

[www.houno.com](http://www.houno.com)

A part of:

