

Data sheet DFIE150_V2



Constructive Features

- cooking vessel in stainless steel AISI 304 (bottom thickness 12mm and wall thickness 2mm) with rounded corners and anti-overflow edge. Vessel motorised on the front axle
- motorised and insulated lid in AISI 304 with food-grade silicone sealing gasket
- self-supporting frame in stainless-steel AISI 430 (thickness 20/10)
- outer cover in stainless steel AISI 304, fine satin finish (thickness 10-20/10)
- adjustable feet in stainless steel AISI 304 to ensure levelling
- protection level IPX5

Functional Features General

- heating by means of thick film heating elements in direct contact with the bottom of the tank
- temperature control via 6(100 lt)/8 (150 lt) probes on the bottom of the tank, 1 probe on the walls, 1 core probe with 3 reading points (5 optional)
- integrated shower head
- socket outlet 230V single-phase 16A
- electronic control by means of multifunctional keyboard with Touch Screen 7" and easy and clear messages
- USB connection to download HACCP data and update the software

Panel Board Functions

- capacitive 7" touch screen
- selection of 3 different cooking modes, with working temperature setting
- cooking type and time setting
- cooking in "Manual" mode
- cooking in "Program" mode
- tank water load setting (hot up to 60°C/cold) with automatic liter measurements
- control for tilting and (automatic) return of the cooking tank from Touch Screen
- control for opening (automatic) and closing of the lid
- language settings touch Screen
- input of different units of measurement (° C/° F ; Liters/gallons ; etc)

Display/Signal

- display type of cooking, set temperature and probe temperature
- heating operating visual alarm
- time to end of cycle display
- display tank out of position for cooking
- self-diagnostics

Safety System

- emergency button
- blocking of heating for excess of temperature with manual resettable safety thermostat
- heating interruption during vat tilting
- prevention of loading large quantities of water
- prevention of water loading and use of the shower when "frying" mode is on

Optionals

- D125 - WHEELS D.125 INOX DFIE..

Accessories

- DAF0150 - STRAINER FOR DFIE.150
- DAP01110 - SHOVEL
- DAP01000 - SPATULA FOR OMELETTE
- DAFF010 - FALSE BOTTOM VESSEL DFIE...
- DAP01140 - LONG HANDLE SCRAPER
- DAP01120 - PERFORATED SHOVEL
- DAPB0150 - GN1/1 DFIE..150 PAN FRAME

Certificates



Planner

.....

.....

.....

.....

.....

.....

.....

.....

.....

.....

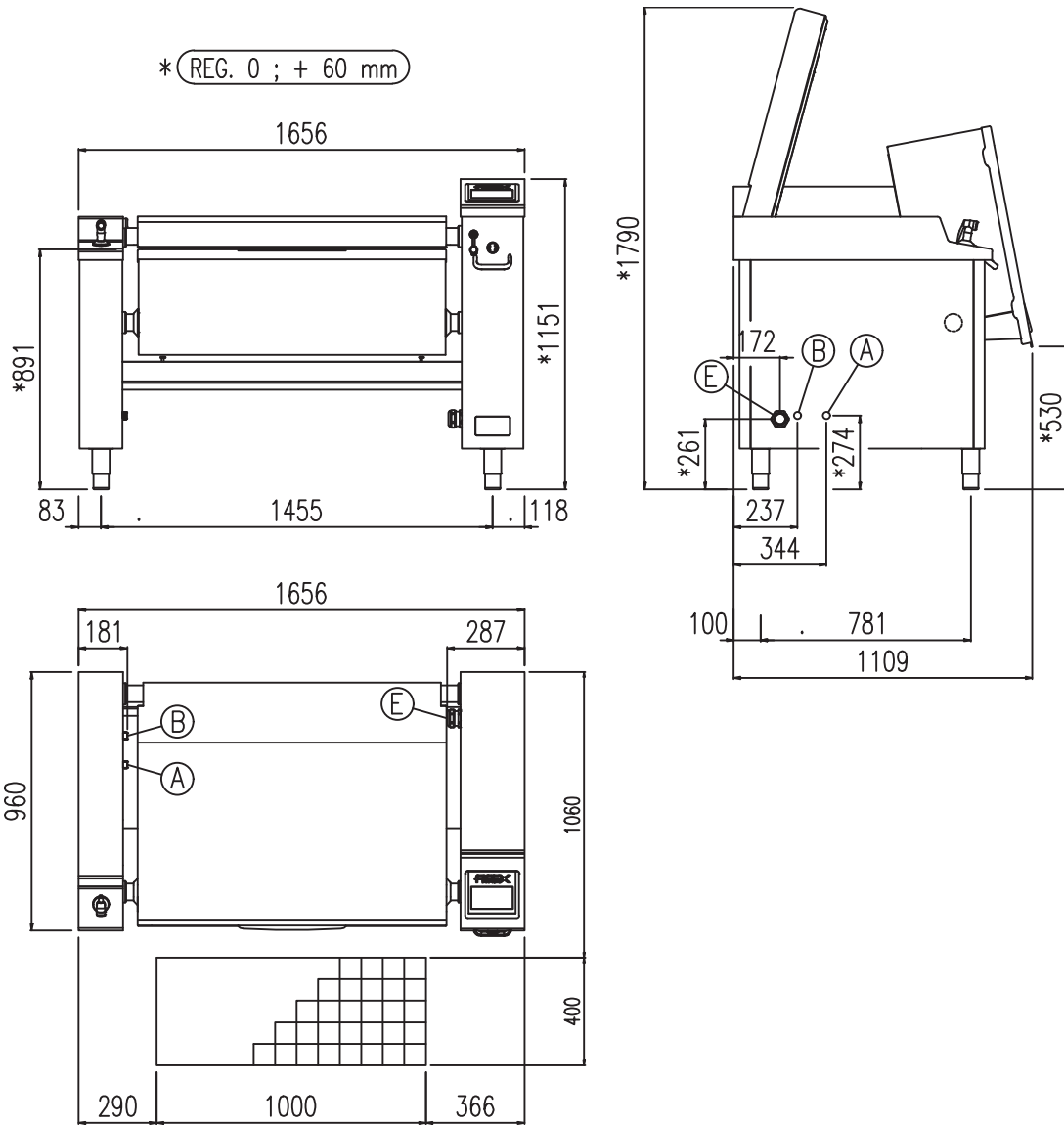

Dimensions weights and capacities

| | | | | | |
|--------|---------|---------------|---------|------------------------|--------------------|
| Width | 1656 mm | Vessel width | 1040 mm | Capacity | 157 lt |
| Depth | 960 mm | Vessel depth | 610 mm | Cooking vessel surface | 63 dm ² |
| Height | 1151 mm | Vessel height | 274 mm | Weight | 360 kg |

Water connection

| | | | | | |
|----------------|-------------|----------------------|------|---------------------|------|
| Water pressure | 150÷400 KPa | Cold water inlet (B) | 3/4" | Hot water inlet (A) | 3/4" |
|----------------|-------------|----------------------|------|---------------------|------|

Electrical connection

| | | | | | |
|-----------------|-----------------------|----------------|----------|---------|-------|
| STD Voltage (E) | 380-415V 3N ~ 50/60Hz | Electric power | 38,50 kW | Current | 64 A |
| OPT Voltage (E) | 208V 3 ~ 50/60Hz | Electric power | 32,00 kW | Current | 100 A |
| OPT Voltage (E) | 220-240V 3 ~ 50/60Hz | Electric power | 38,50 kW | Current | 110 A |